



## PRINT & CUT Issues and Solutions for the FC9000 Series

If the Graphtec FC9000 is new to the operator, the first step is to review our [FC9000 TRAINING VIDEOS](#) to get familiar with the cutter before proceeding.

**3 Issues can come up with the FC9000 during Print & Cut applications:**

- **Sensor not Scanning Registration Marks**
- **Sensor Scans Marks, but Cuts are Off**
- **Barcode Function not Working**

### **Sensor Not Scanning Registration Marks**

When the FC9000 sensor is not scanning registration marks, it can be caused by:

**Machine Error** (print, operator error, sensor)

**Connection Error** (USB, Serial, Ethernet)

**Computer Error** (file, software)

- A. If the operator has already used the Print & Cut feature successfully, we recommend trying a different file, even if the file has been cut successfully before.
- B. If the sensor does not scan the marks on the new file, follow troubleshooting **STEPS 1 - 4** in sequence before contacting the Graphtec technical support team.

### **STEP 1: Selecting the Load Media**

Make sure Roll 1 or Sheet (if print is on a sheet) is selected when initializing cutter.  
DO NOT select Roll 2 for a print and cut job.

- ***If problem persists proceed to STEP 2***

### **STEP 2: Using Specialty Media**

If you are cutting **High Intensity Reflective**, or **Prismatic Media**, please confirm that the cutter firmware is current. Firmware can be found here: [GRAPHTEC FIRMWARE PAGE](#)

If firmware is current, watch the Instructional Video: [CUTTING SPECIALTY MEDIA](#)

- ***If problem persists proceed to STEP 3***

### **STEP 3: Confirming Proper Sensor Operation**

Check the Cutter Sensor by performing an ARMS TEST

Print the **ARMS Test Sheet** PDF on a desktop printer

*(The ARMS Test Sheet file is located on the CD that came with your machine).*

Watch Instructional Video: [ARMS TEST](#)

**ARMS TEST is successful when all marks are read.**

*(Since we are not scanning marks, no need to load a tool or pen)*

If successful, the issue is NOT in the machine.

- ***If problem persists proceed to step 4***

**If ARMS TEST is unsuccessful:**

Reset cutter to factory default. Before resetting, make sure to write down your cutting conditions as they will go back to default.

Watch Instructional Video: [FACTORY RESET](#)

If **ARMS TEST** is still unsuccessful after reset, record a video of the ARMS Test procedure and contact [Graphtec Technical Support:](#)

### **STEP 4: Checking Connection / Software**

- If using USB connection, make sure cable is less than 15ft with no hubs or adaptors.
- Remove all adaptors and connect directly for test purposes. Replace USB cable.
- If Ethernet connection, try via USB, note the above instructions. If successful via USB contact your network administrator or IT to check network.

If the above items are OK and you are using software such as Onyx/Flexi/Etc., try cutting a job using [Graphtec Cutting Master 4](#)

- **If successful via Graphtec Software**, please contact 3<sup>rd</sup> party software manufacturer. Be sure to let them know the cutter will work with Graphtec software.
- **If unsuccessful via Graphtec Software** contact [Graphtec Technical Support:](#)

## **Sensor Scans Marks, but Cuts are OFF**

Proper alignment of media and push roller positioning is important:

**Refer to Loading Media Section in User Manual before contacting support.**

- *Watch Instructional Video:* [FC9000 - LOADING MEDIA](#)

There is an internal test/adjustment in the cutter's menu called **Sensor Offset Adjust**. This test will confirm if the issue is coming from the cutter. If so, it will allow the end users to adjust the sensor calibration:

- *Watch Instructional Video:* [SENSOR OFFSET ADJUST](#)

Take note of any previous jobs that were successful, or if using specialty media. Isolate the problem by trying a different file before contacting Tech Support.

If issue ONLY happens when cutting Specialty Media, ensure cutter firmware is current.

- *Watch Instructional Video:* [HOW TO UPDATE FIRMWARE](#)

If the sensor offset adjust shows the same offset as cut jobs, adjust accordingly.

If not, then the machine is working normally, proceed to perform the following troubleshooting steps based on the offset you are seeing:

### **STEP 1: Check Blade Holder Position**

If offset is 1/4" in the X direction, please check if blade holder is loaded in correct tool position. If it is loaded in the correct position, check that the **Assign Tool** option in the **Conditions Menu** is selected:

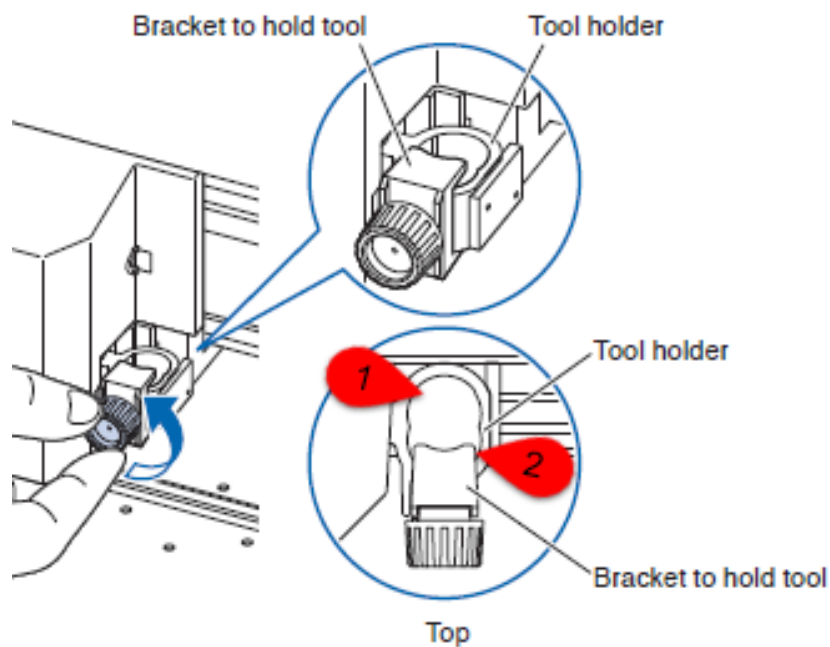

### **STEP 2: Sensor Offset Adjustment**

If offset is uniform in same direction, check and adjust sensor via Sensor Offset Adj:

- Watch Instructional Video: [SENSOR OFFSET ADJUST](#)
- If the sensor calibration looks correct, but cuts are still off, go to **Step 3**

### **STEP 3: Check Connection**

If Sensor Offset Adjust looks normal and issue persists, or if the offset on print jobs is NOT uniform, the connection and software should then be tested.

- If using USB connection, make sure cable is less than 15ft with no hubs or adaptors.
- Remove all adaptors and connect directly for test purposes. Replace USB cable.
- If Ethernet connection, try via USB, note the above instructions. If successful via USB contact your network administrator or IT to check network.

If the above items are OK and you are using software such as Onyx/Flexi/Etc., try cutting a job using [Graphtec Cutting Master 4](#)

- **If successful via Graphtec Software**, please contact 3<sup>rd</sup> party software manufacturer. Be sure to let them know the cutter will work with Graphtec software.
- **If unsuccessful via Graphtec Software** contact [Graphtec Technical Support:](#)

### **Barcode Function not Working:**

If Barcode Function is new to the operator, make sure to view the instructional video on the DataLink Barcode Feature:

- *Watch Instructional Video:* [FC9000 - DATALINK BARCODE FEATURE](#)

If the cutter is able to read registration marks on jobs with no barcode, the issue is NOT the cutter.

When using barcodes, the sensor takes 4 steps before cutting the job.

- 1- Sensor reads the START MARK**
- 2- Sensor reads the BARCODE**
- 3- Job file is retrieved from Software or USB**
- 4- Sensor reads the REGISTRATION MARKS**

## **STEP 1: START MARK Position**

If the START MARK is not read by the sensor:

- Check that **Roll 1** or **Sheet** is selected to initialize cutter. **DO NOT select Roll 2**
- Allow at least **1" Space** between LEADING EDGE of the media and START MARK.
- If START MARK is still not being read by sensor, record a video of the issue and then contact [Graphtec Technical Support:](#)

## **STEP 2: Barcode Print Resolution**

If the barcode is not read by the sensor, the issue is probably barcode print resolution.

- Make sure cutter software and firmware is current.
- Increase the print resolution on the printer or check print settings.
- Select a longer barcode in the software

## **STEP 3: Destination – File Retrieval**

If the issue is with file retrieval after scanning of the barcode.

- Check that the **Destination** option in the Data Link menu is selected.
- Check that the DataLink is set in the Software.

### **CHECK YOUR CONNECTION:**

- If using USB connection, make sure cable is less than 15ft with no hubs or adaptors.
- Remove all adaptors and connect directly for test purposes. Replace USB cable.
- If Ethernet connection, try via USB, note the above instructions. If successful via USB contact your network administrator or IT to check network.

If the above items are OK and you are using software such as Onyx/Flexi/Etc., try cutting a job using **Graphtec Cutting Master 4**

- **If successful via Graphtec Software**, please contact 3<sup>rd</sup> party software manufacturer. Be sure to let them know the cutter will work with Graphtec software.
- **If unsuccessful via Graphtec Software** contact [Graphtec Technical Support:](#)

[How to Enable DataLink in Onyx](#)